

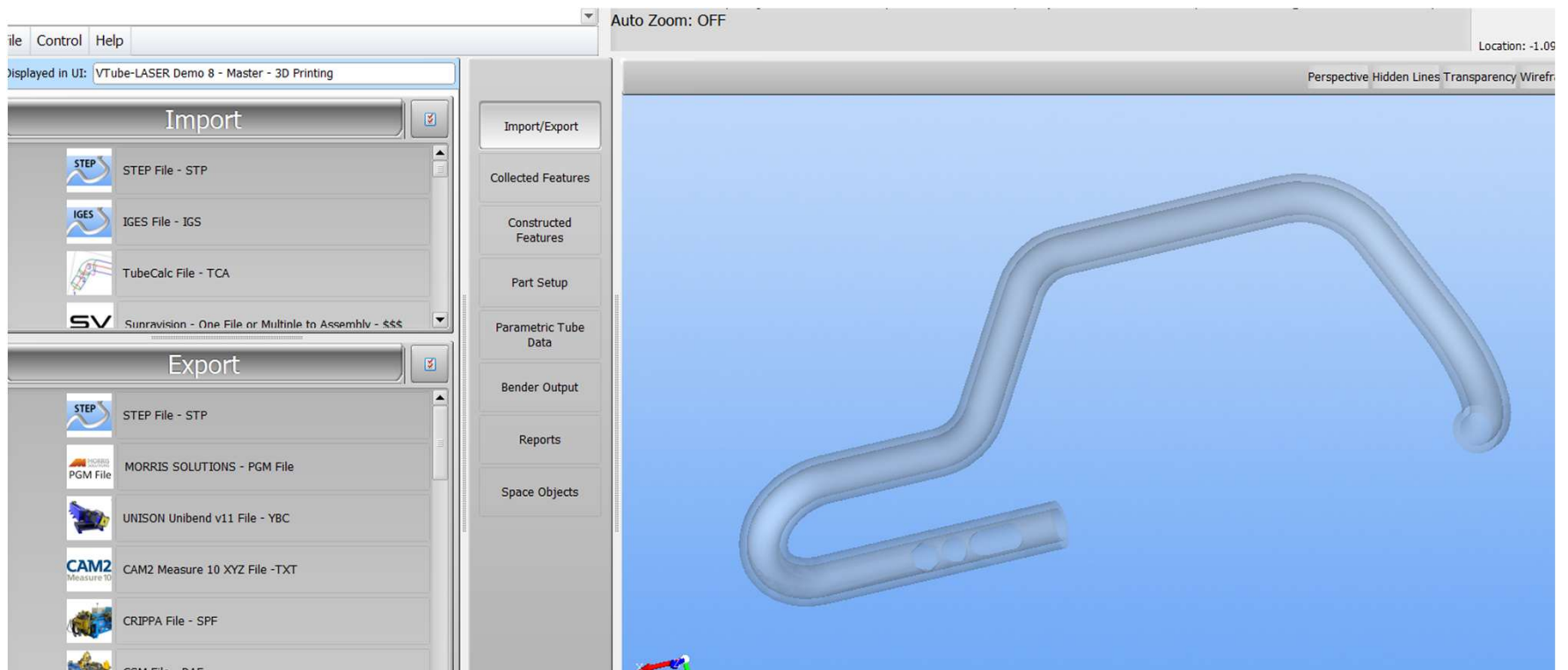

Workflow for VTube-LASER

Importing and Measuring a
Polygon

Import your 3D model



Go to Space Objects > CIRCLE: From 3 Polygon Model Surfaces

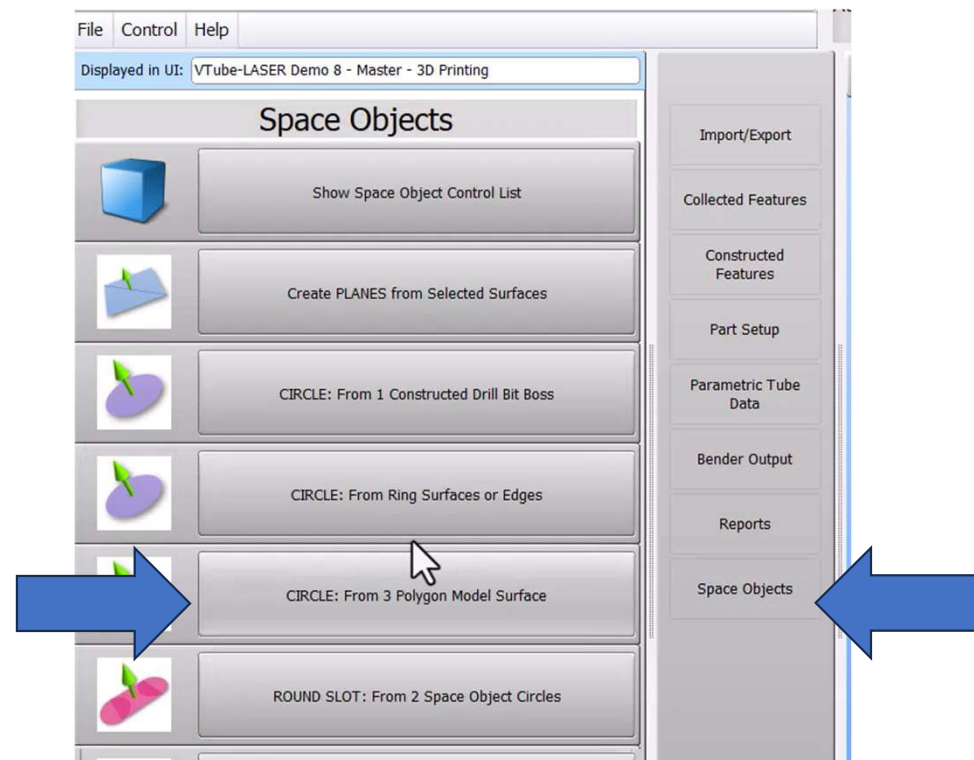

Click on “Start Selecting 3 MULTIPLE SURFACES”

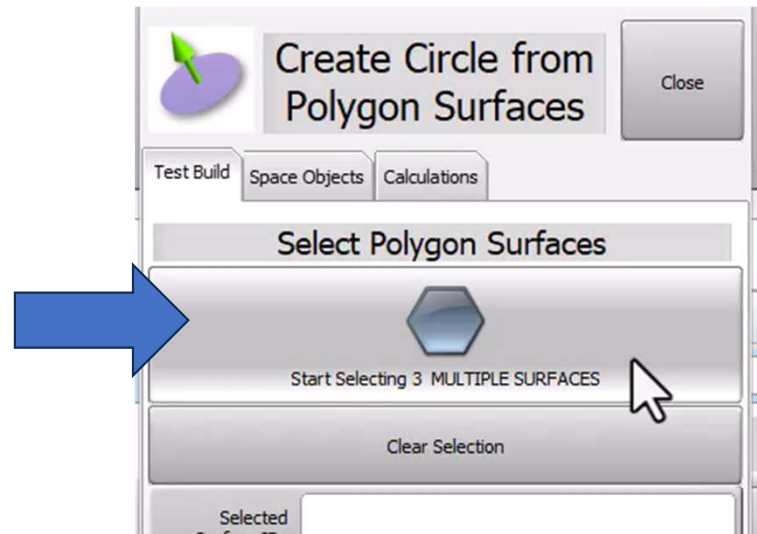

Click on one side of the polygon and then hold the SHIFT key down. Now select two more sides

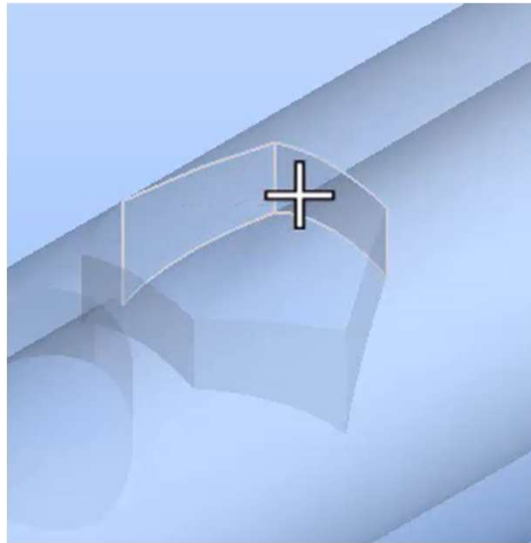

Right click after three sides have been collected to accept the sides. They should turn green

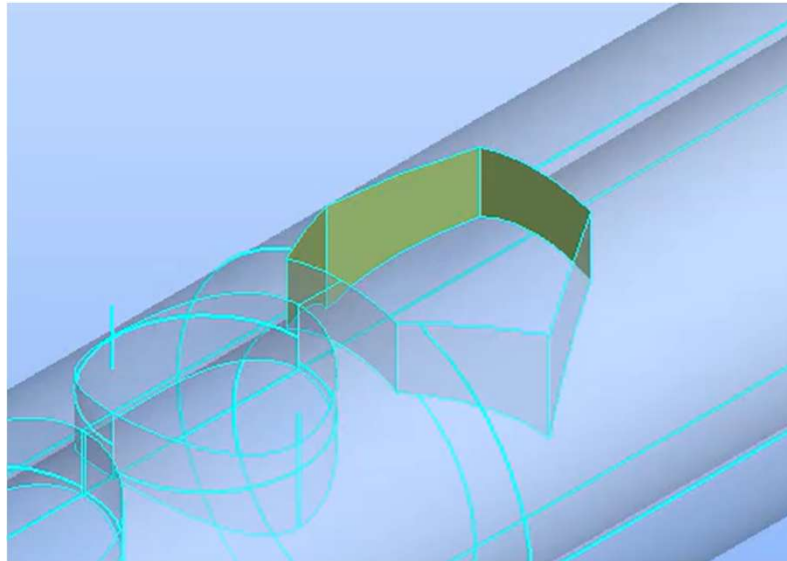

Perform a Test Build to ensure the location of the circle is correct

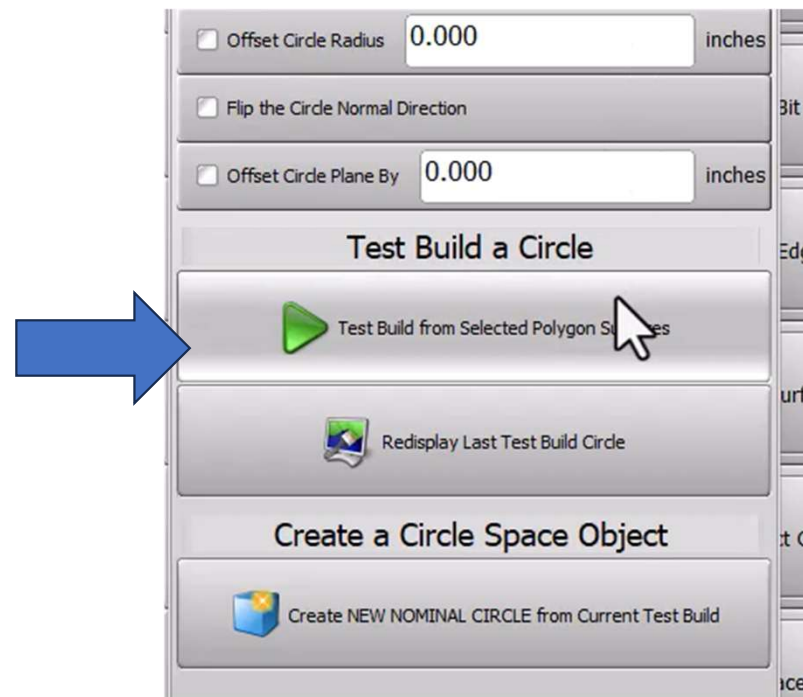

If it is not in the correct location, check or uncheck boxes under “Filter Setup For Build” and re-test

Incorrect placement because the circle is not on the face of the tube

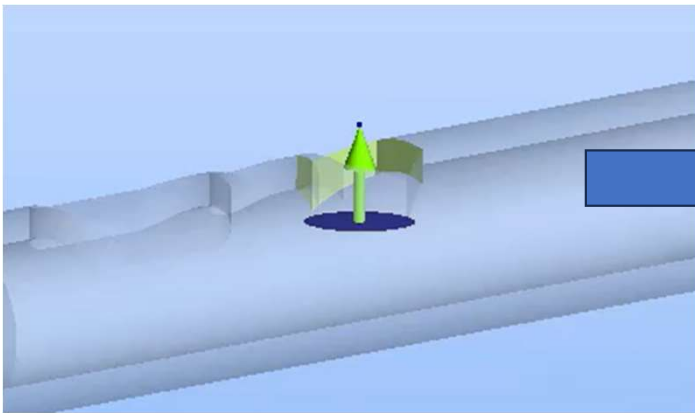

Use the other end of the hole for trim was checked

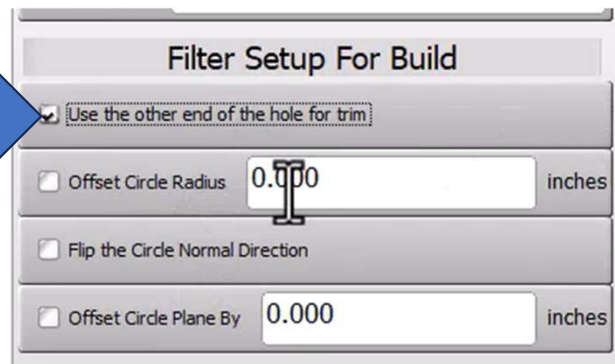

Re-test and see the circle on the face of the tube. This is correct

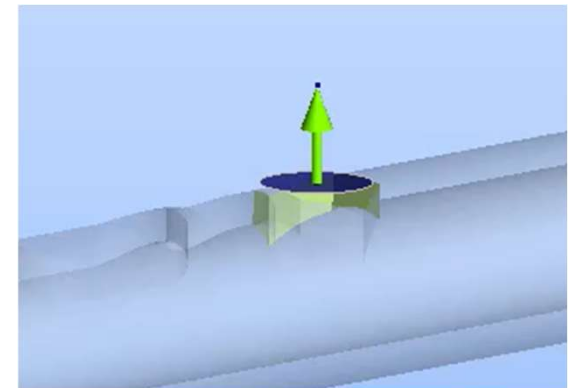

Once the circle is in the correct location, create a Space Object and rename as needed

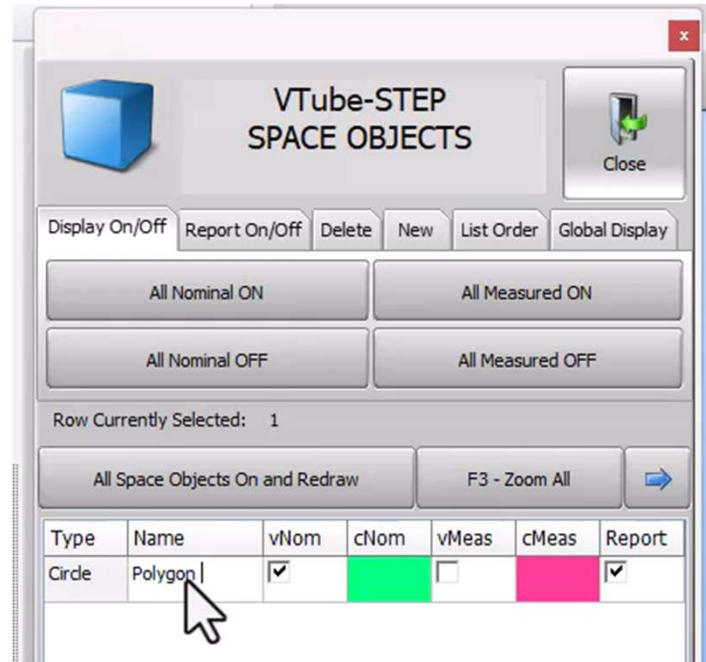
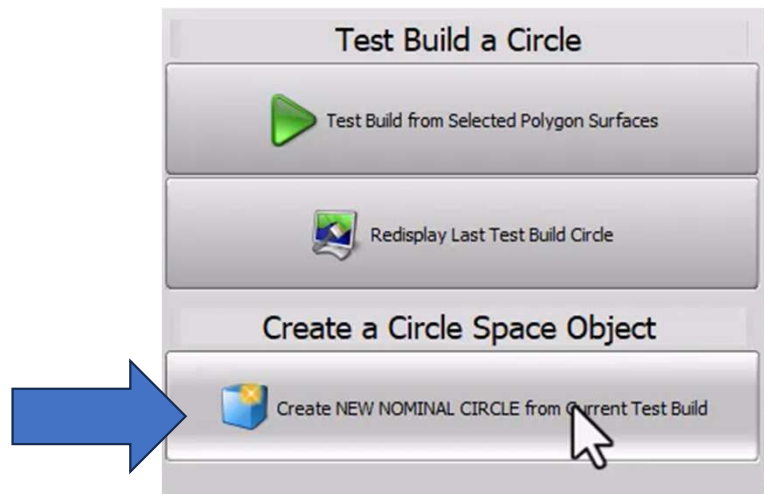

Go to Collected Features > Show Collect Control

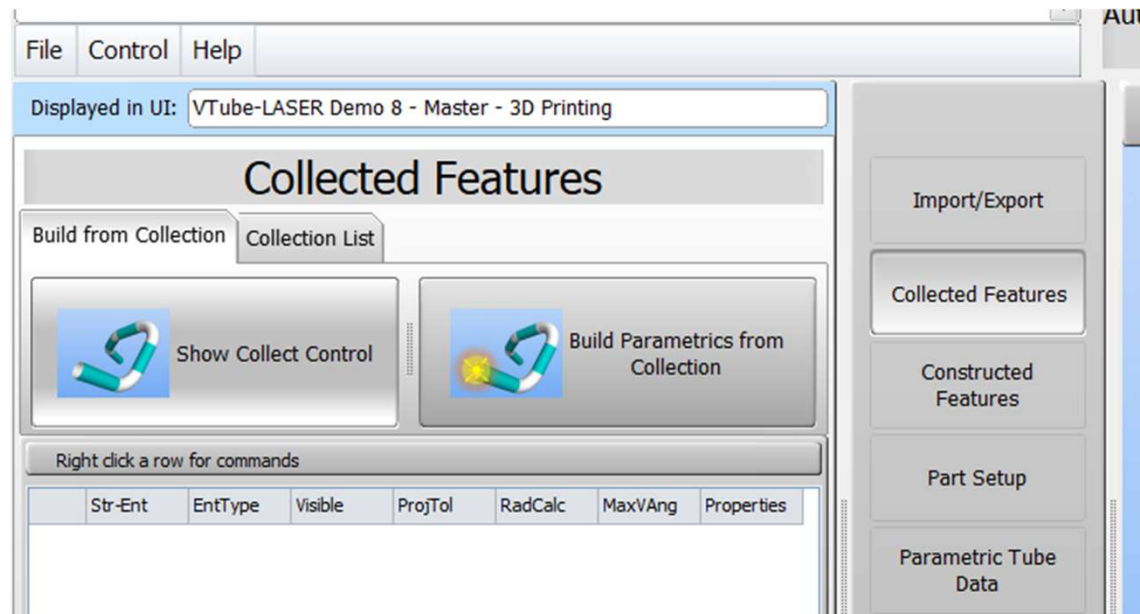

Collect your tube cylinders

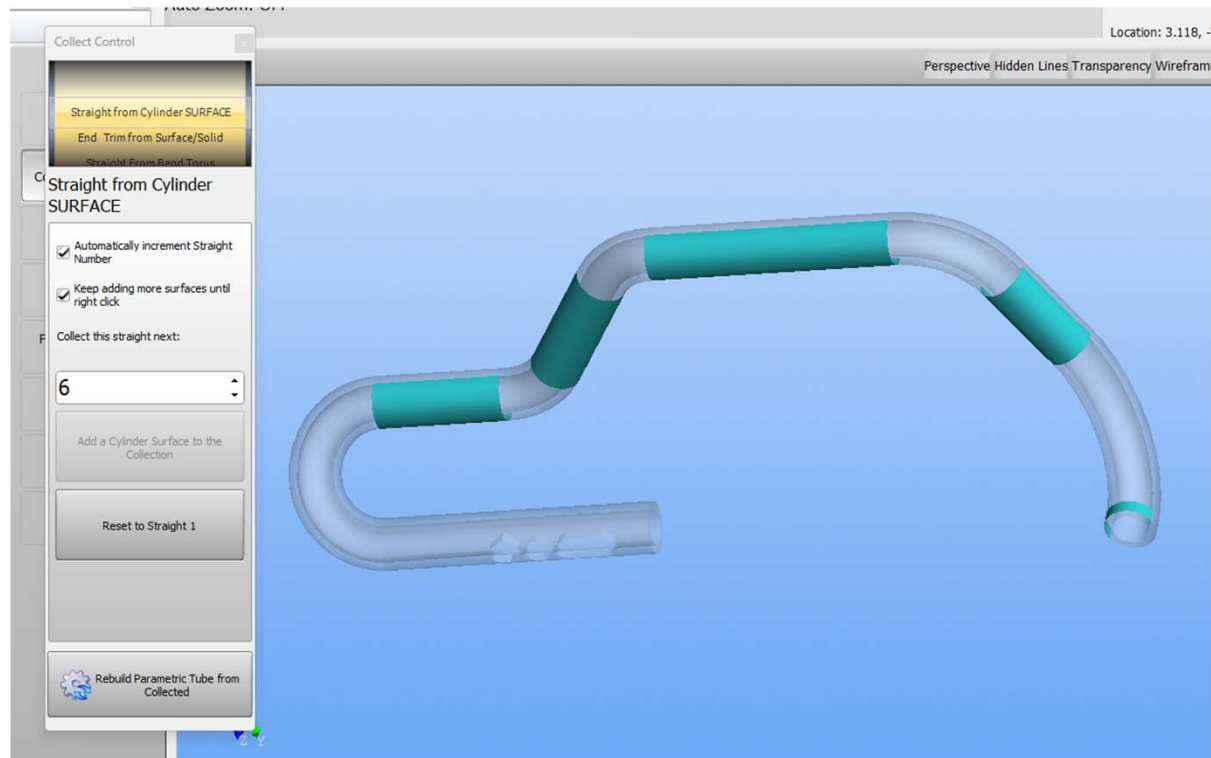

Rebuild Parametric Tube from Collected

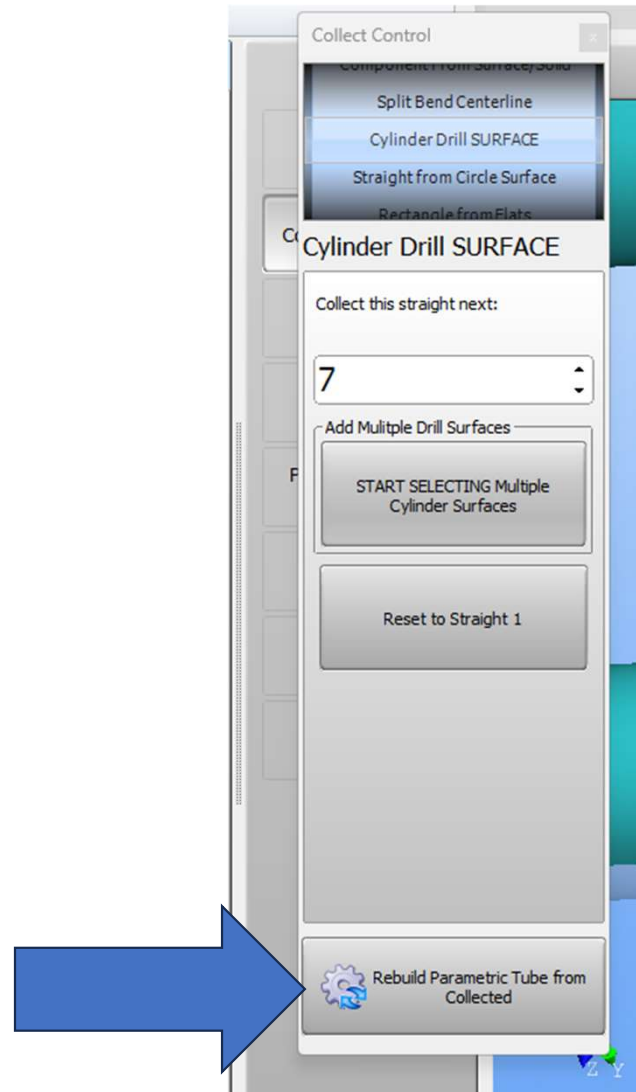

Repeat this process for all polygons

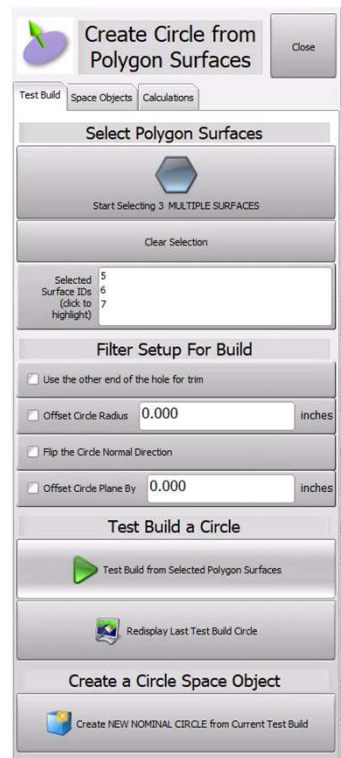

Measure the main body of the tube as normal

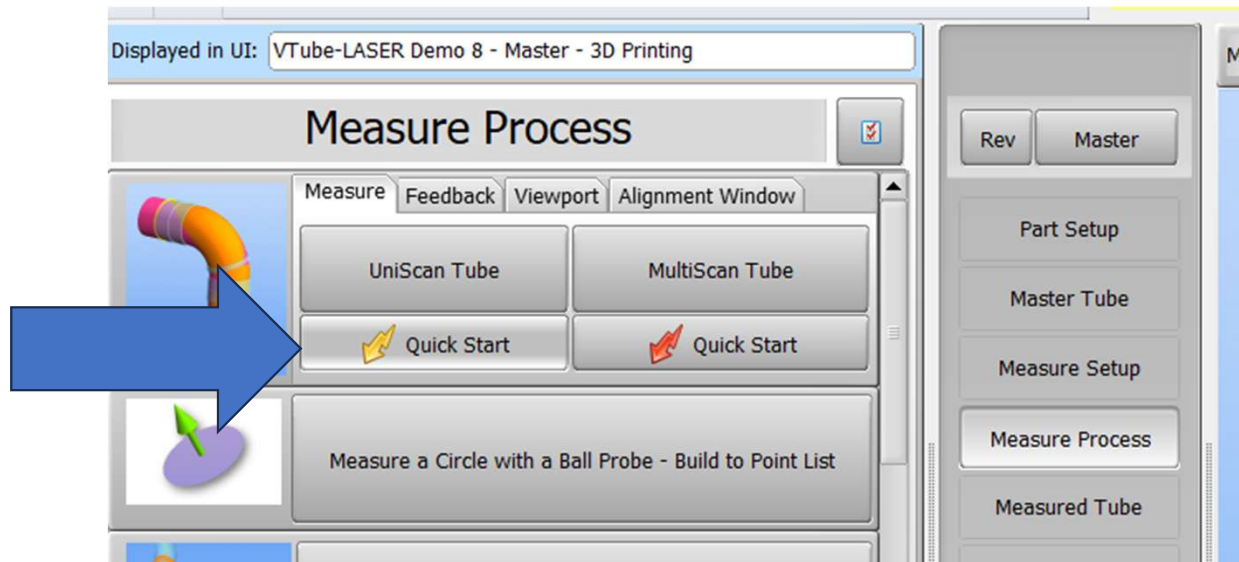

Align measured to master

After-Measure Alignment

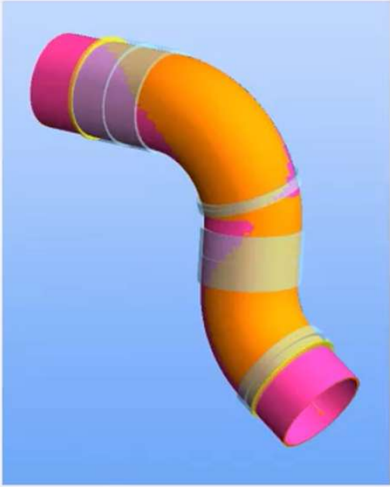

Align using this algorithm

Best Fit Alignment 5

Display a report automatically

Show a report after alignment

Choose the report template to use:

Tube Inspection Report

Align measured to master now

Copy measured to master and close this window

Skip the alignment and close window

The image shows a software interface for aligning a measured part to a master. On the left, a 3D model of a curved pipe is shown with several colored bands (yellow, purple, pink) indicating measurement points. The main panel contains settings for the alignment algorithm, a checkbox for automatic report generation, and a dropdown menu for the report template. On the right, there are three buttons: 'Align measured to master now' (with a mouse cursor icon), 'Copy measured to master and close this window' (with a blue arrow icon), and 'Skip the alignment and close window' (with a green arrow icon).

Change the Coordinate System from Arm CS to the most recent Measured Aligned Tube.

NOTE: The tube CANNOT move between the main measure and measuring the circle

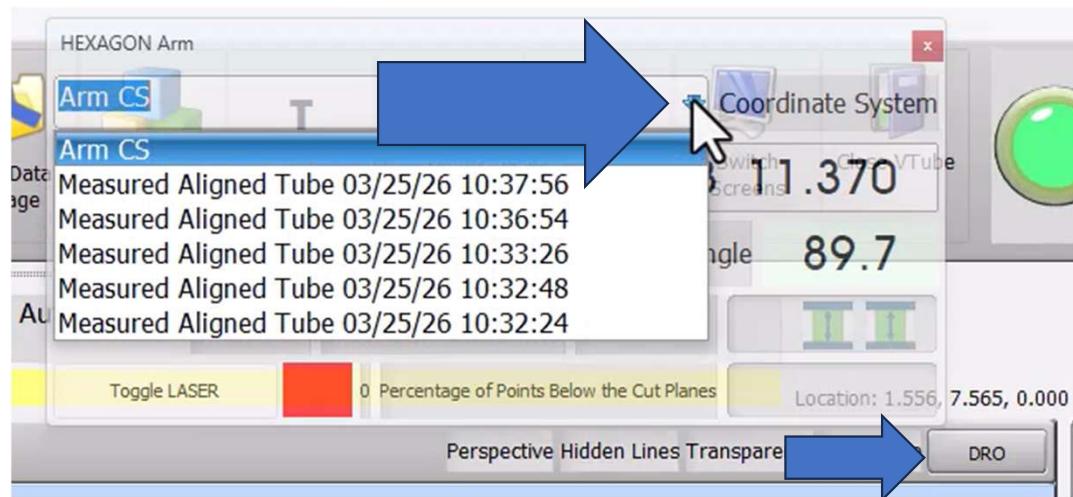

Go back to measure process and select Measure a Circle with a Ball Probe

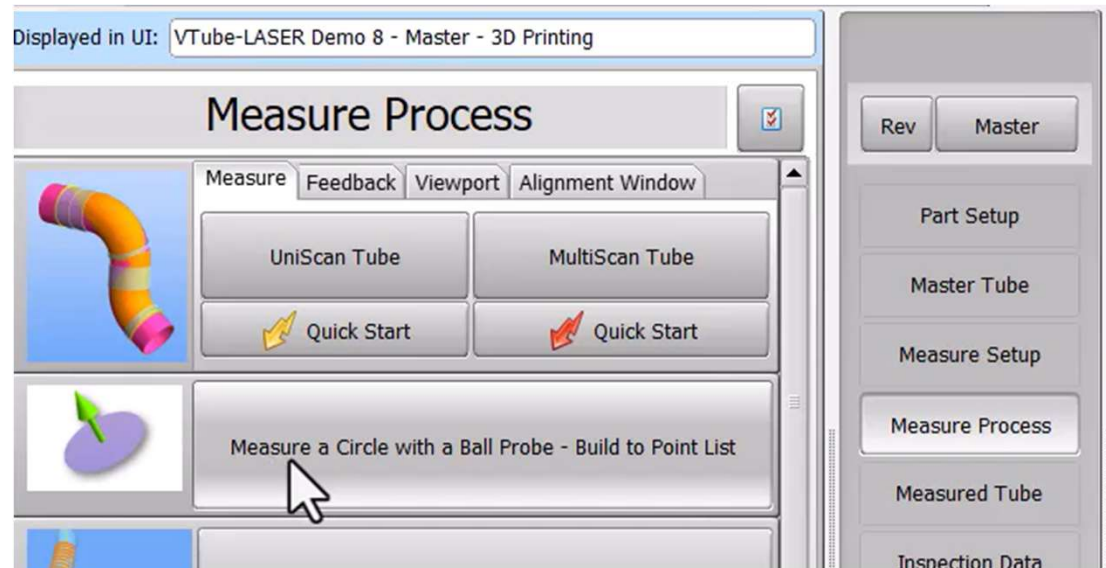

Toggle the LASER OFF

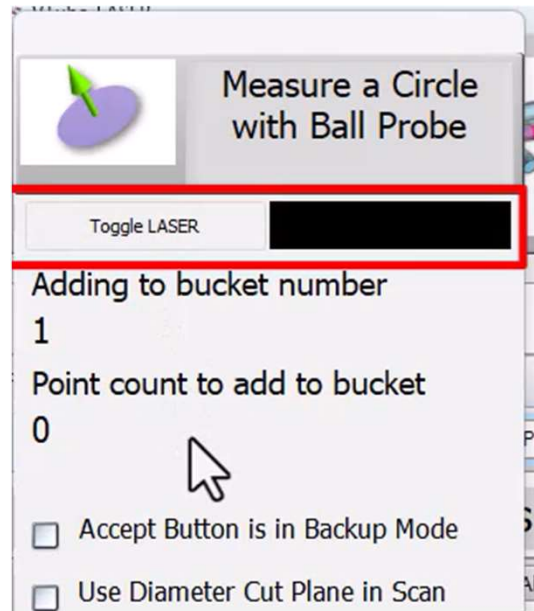

Measure 3 points around the perimeter of the polygon and a fourth point in the center as an offset point. Click the rubber button on the arm left or right to accept

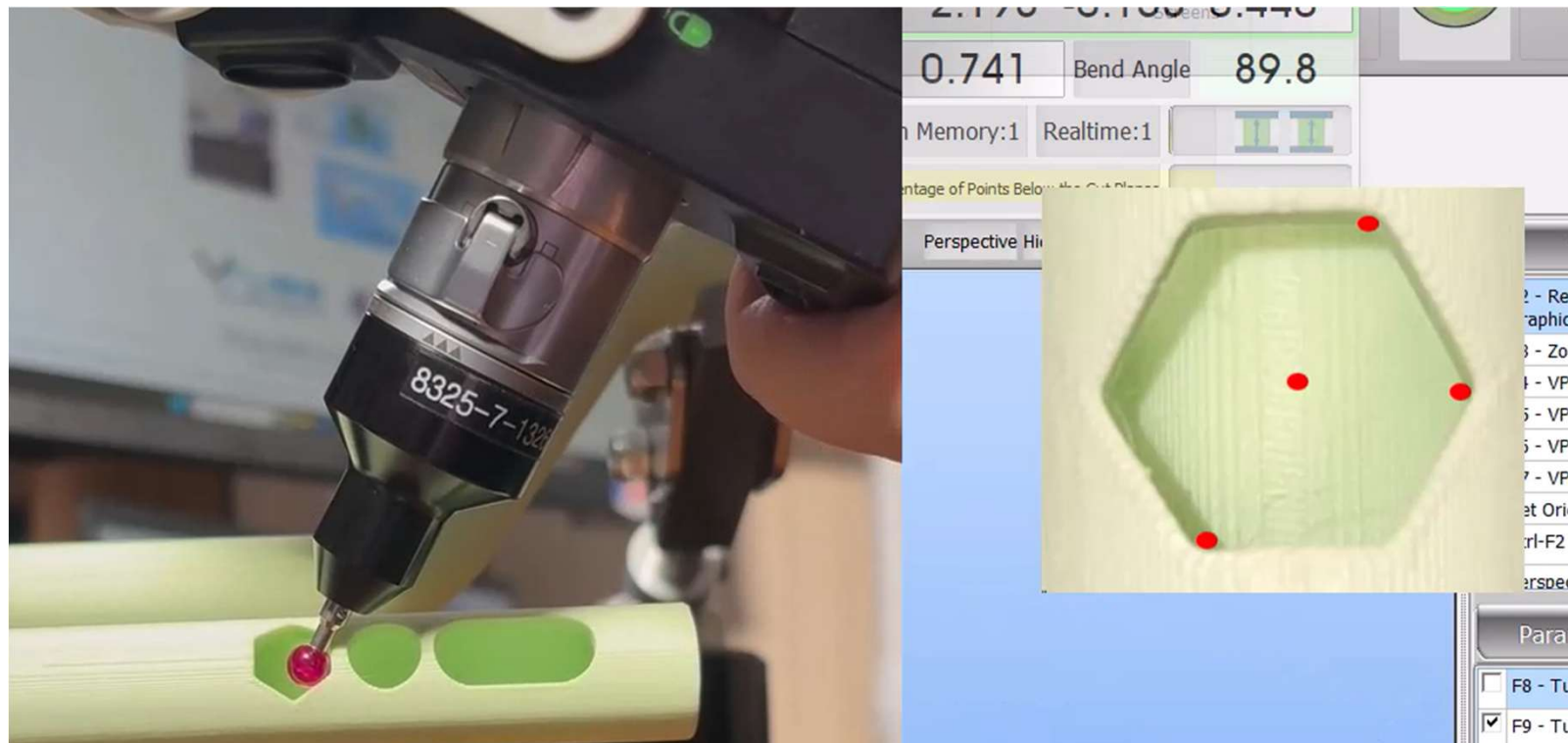

Go to the Build Existing tab and select the Space Object circle for the polygon you just measured. Then press “Insert into Existing Circle”

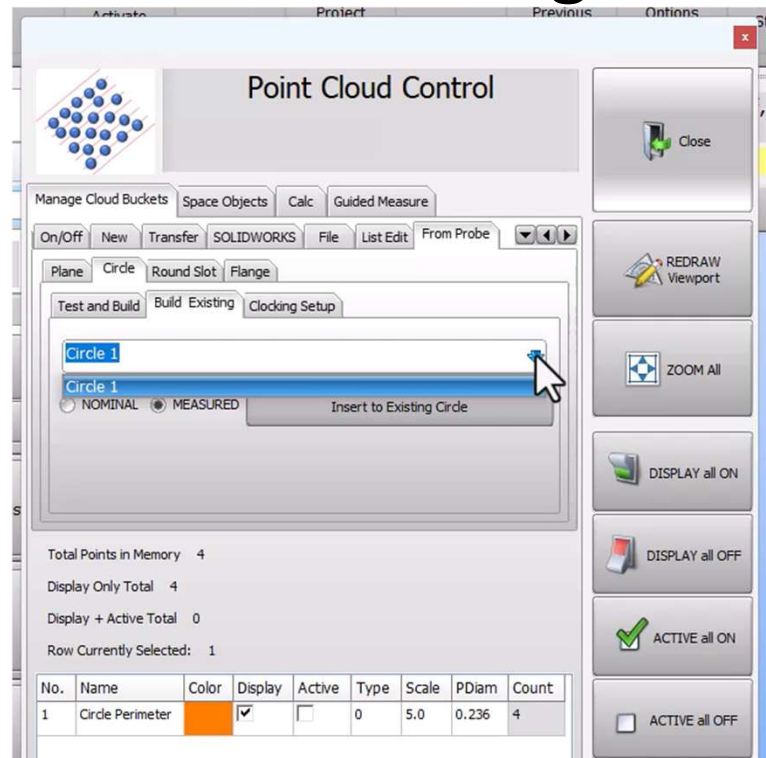

Expand the tabs to view the information

The screenshot displays the VTube-LASER SPACE OBJECTS software interface. The main window is titled "Circle 'Circle 1'" and contains two tabs: "General Metrics" and "Tube Straight Metrics". The "General Metrics" tab is active, showing a table of measurement data. The table has columns for Name, Nominal, Measure, Report, Qualify, Deviatio, Toleran, and OOT. The data rows include Center X, Center Y, Center Z, Center True Position, Vector I, Vector J, Vector K, Diameter, Radius, High Side Deviation, Low Side Deviation, Flatness (Total Deviation), and Flatness Standard Deviation. The "Report" column for all rows contains checkboxes, and the "Deviatio" and "OOT" columns contain numerical values. The "Measure" column for "Center True Position" is highlighted in blue, and the "Report" checkbox for "Center True Position" is checked. The "Type" column in the table below the main window is highlighted in blue, and the "Name" column is highlighted in green. The "vNom" column is checked, and the "vMeas" column is checked. The "cMeas" column is highlighted in pink.

VTube-LASER
SPACE OBJECTS

Close

Display On/Off Report On/Off Delete New List Order Global Display

All Nominal ON All Measured ON

All Nominal OFF All Measured OFF

Row Currently Selected: 1

All Space Objects On and Redraw F3 - Zoom All

Type	Name	vNom	cNom	vMeas	cMeas	Report
Circle	Circle 1	<input checked="" type="checkbox"/>		<input checked="" type="checkbox"/>		<input checked="" type="checkbox"/>

Circle "Circle 1"

General Metrics Tube Straight Metrics

Name	Nominal	Measure	Report	Qualify	Deviatio	Toleran	OOT
Center X	1.654	20.764	<input type="checkbox"/>	<input type="checkbox"/>	0.000	0.000	0.000
Center Y	0.000	-1.576	<input type="checkbox"/>	<input type="checkbox"/>	0.000	0.000	0.000
Center Z	0.367	11.363	<input type="checkbox"/>	<input type="checkbox"/>	0.000	0.000	0.000
Center True Position	0.000	22.104	<input checked="" type="checkbox"/>	<input type="checkbox"/>	0.000	0.000	0.000
Vector I	0.00047809	0.30530602	<input type="checkbox"/>	<input type="checkbox"/>	0.000	0.000	0.000
Vector J	-0.00027590	0.95048941	<input type="checkbox"/>	<input type="checkbox"/>	0.000	0.000	0.000
Vector K	0.99999985	-0.05794920	<input type="checkbox"/>	<input type="checkbox"/>	0.000	0.000	0.000
Diameter	0.394	0.450	<input type="checkbox"/>	<input type="checkbox"/>	0.000	0.000	0.000
Radius	0.197	0.225	<input type="checkbox"/>	<input type="checkbox"/>	0.000	0.000	0.000
High Side Deviation	0.000	0.000	<input type="checkbox"/>	<input type="checkbox"/>	0.000	0.000	0.000
Low Side Deviation	0.000	0.000	<input type="checkbox"/>	<input type="checkbox"/>	0.000	0.000	0.000
Flatness (Total Deviation)	0.000	0.000	<input type="checkbox"/>	<input type="checkbox"/>	0.000	0.000	0.000
Flatness Standard Deviation	0.000	0.000	<input type="checkbox"/>	<input type="checkbox"/>	0.000	0.000	0.000

Click on Report and Qualify if you'd like to save the information to a report and set the tolerance

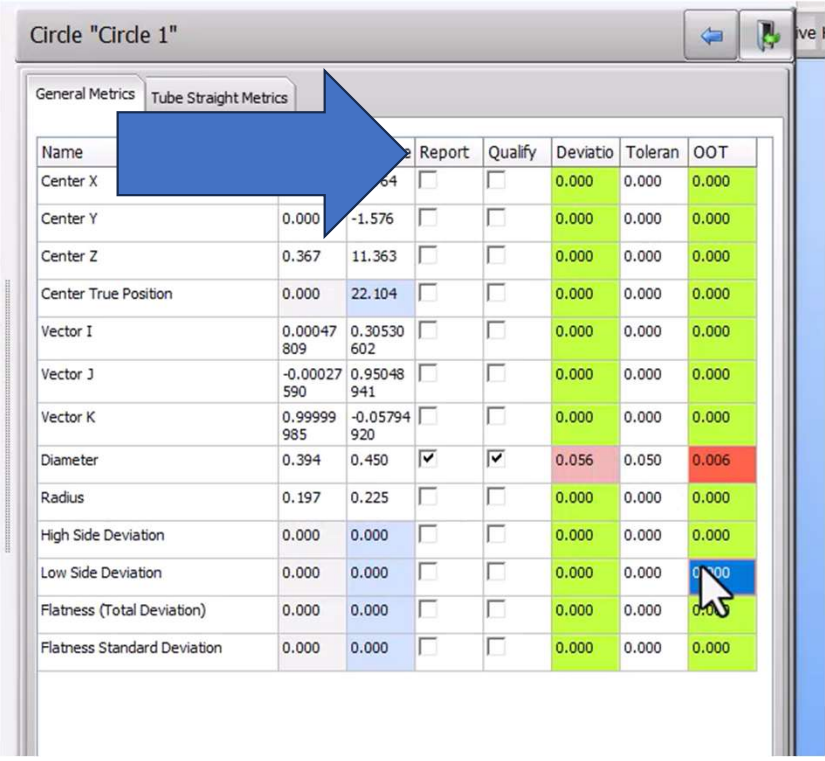

Circle "Circle 1"

General Metrics Tube Straight Metrics

Name	Report	Qualify	Deviatio	Toleran	OOT
Center X	<input type="checkbox"/>	<input type="checkbox"/>	0.000	0.000	0.000
Center Y	<input type="checkbox"/>	<input type="checkbox"/>	0.000	0.000	0.000
Center Z	<input type="checkbox"/>	<input type="checkbox"/>	0.000	0.000	0.000
Center True Position	<input type="checkbox"/>	<input type="checkbox"/>	0.000	0.000	0.000
Vector I	<input type="checkbox"/>	<input type="checkbox"/>	0.000	0.000	0.000
Vector J	<input type="checkbox"/>	<input type="checkbox"/>	0.000	0.000	0.000
Vector K	<input type="checkbox"/>	<input type="checkbox"/>	0.000	0.000	0.000
Diameter	<input checked="" type="checkbox"/>	<input checked="" type="checkbox"/>	0.056	0.050	0.006
Radius	<input type="checkbox"/>	<input type="checkbox"/>	0.000	0.000	0.000
High Side Deviation	<input type="checkbox"/>	<input type="checkbox"/>	0.000	0.000	0.000
Low Side Deviation	<input type="checkbox"/>	<input type="checkbox"/>	0.000	0.000	0.000
Flatness (Total Deviation)	<input type="checkbox"/>	<input type="checkbox"/>	0.000	0.000	0.000
Flatness Standard Deviation	<input type="checkbox"/>	<input type="checkbox"/>	0.000	0.000	0.000

You can see more information under the Tube Straight Metrics tab after linking the circle to the correct straight

Circle "Circle 1"

General Metrics Tube Straight Metrics

Note: The calculated values for the Space Object NOMINAL values are always linked to the MASTER part.

✔ Link this Space Object to a tube straight

Link to Straight Number: 7

Measured Space Object Calcs Link To: MEASURED-ALIGNED Tube

Name	Nominal	Measure	Report	Qualify	Deviatio	Toleran	OOT
NormV Nearpass Distance	0.002	11.292	<input type="checkbox"/>	<input type="checkbox"/>	0.000	0.000	0.000
NormV Angle to Previous Bend Plane	134.9	44.4	<input type="checkbox"/>	<input type="checkbox"/>	0.0	0.0	0.0
NormV Angle to Next Bend Plane	0.0	0.0	<input type="checkbox"/>	<input type="checkbox"/>	0.0	0.0	0.0
NormV to Centerline Vector	90.0	107.6	<input type="checkbox"/>	<input type="checkbox"/>	0.0	0.0	0.0
INVERTED - NormV Angle to Previous Bend Plane	45.1	135.6	<input type="checkbox"/>	<input type="checkbox"/>	0.0	0.0	0.0
INVERTED - NormV Angle to Next Bend Plane	0.0	0.0	<input type="checkbox"/>	<input type="checkbox"/>	0.0	0.0	0.0
INVERTED - NormV Angle to Centerline Vector	90.0	72.4	<input type="checkbox"/>	<input type="checkbox"/>	0.0	0.0	0.0
Clock from Previous Bend Plane (Circ in Front)	134.8	127.5	<input type="checkbox"/>	<input type="checkbox"/>	0.0	0.0	0.0
Clock from Next Bend Plane (Circ in Front)	0.0	0.0	<input type="checkbox"/>	<input type="checkbox"/>	0.0	0.0	0.0

View the information you wish to see on the Space Objects report

The screenshot displays the VTube-LASER software interface. On the left, the 'Reports' menu is open, showing a list of report templates. A blue arrow points to the 'Space Objects' report template. The main window, titled 'VTube Report', is open, showing a 3D model of a tube assembly and a 'Space Objects Qualification List' table.

Report Templates

	Name	Format
1	Tube Inspection Report	HTML
2	Thales	HTML
	Tube Inspection - SAE J2551-1	HTML
	Space Objects	HTML
6	End Trim Profile Report	HTML
	Straight Cylinder Profile Data	HTML
7	Bend Profile Qualification Report	HTML
8	VTube-LASER Scan Score	HTML
9	Long Inspection Report	HTML

VTube Report

Print | Export to PDF | Export to File | Setup | Preview

Print | Print + Quick Export | Quick Export | Close

Press Quick Export to send backups of this report to path: C:\Users\Public\Documents\VTube\

VTube REPORT

VTube-LASER Demo 8 - Master - 3D Printing

Date/Time: 3/25/2026 10:53:11 AM
Part Number: VTube-LASER Demo 8 - Master - 3D Printing

Space Objects Qualification List

Object Name	Metric	Nom	Meas	Dev	Tol	OOT
Circle 1	Diameter	0.394	0.450	0.056	0.050	0.006